

ACVATIX™

## Butterfly valves PN 16

VFF41..



- Concentric, double flanged type
- Nodular cast iron valve body
- DN 40...900
- $k_{vs}$  55...74,020 m<sup>3</sup>/h
- For fitting with PN 16 counter-flanges to ISO 7005
- Tight-closing in accordance with ISO 5208, leakage rate A
- No maintenance required
- Can be equipped with SQL321B., SQL361B., and SQL351... electromotoric actuators

## Use

This device is used as motorized or shut-off valves in heating, ventilation and air conditioning systems applications.

- In open and closed circuits
- For 2-position (SPDT) (by SQL321B...)
- For DC 0...10 V control signals (by SQL361B.. actuator) and 4...20 mA control signals (by SQL351B.. actuator)
- For chiller and cooling tower sequencing circuits
- To open or close the flow to a heat exchanger or to complete plant sections

## Type summary

Product number	Stock number	DN	K <sub>vs</sub>	Top Flange	Flow velocity of medium <sup>1)</sup>
			[m <sup>3</sup> /h]	EN ISO 5211	Water [m/s]
VFF41.40	S55235-V137	40	55	F07	4.5
VFF41.50	S55235-V120	50	70		
VFF41.65	S55235-V121	65	155		
VFF41.80	S55235-V122	80	250		
VFF41.100	S55235-V123	100	510		
VFF41.125	S55235-V124	125	820		
VFF41.150	S55235-V125	150	1350		
VFF41.200	S55235-V126	200	3100	F10	
VFF41.250	S55235-V127	250	4550		
VFF41.300	S55235-V128	300	7500	F12	
VFF41.350	S55235-V129	350	10250		
VFF41.400	S55235-V130	400	14100	F14	
VFF41.450	S55235-V131	450	18500		
VFF41.500	S55235-V132	500	24000	F16	
VFF41.600	S55235-V133	600	37000		
VFF41.700	S55235-V134	700	42420	F25	
VFF41.800	S55235-V135	800	58490		
VFF41.900	S55235-V136	900	74020		

1) Recommended maximum velocity of flow and the butterfly valve fully open

K<sub>vs</sub> Nominal flow rate of cold water (5...30 °C) through the fully open butterfly valve by a differential pressure of 100 kPa (1 bar)

## Ordering

Butterfly valve, actuator must be ordered separately.

When ordering, please specify the quantity, product name and product number.

Example:

Product No.	Stock No.	Product Name	Quantity
VFF41.150	S55235-V125	Butterfly valve	1

## Delivery

- Butterfly valve and actuator are packed separately.

## Rev. No.

- Please see chapter "Revision numbers" on page 10.

## Equipment combinations

Butterfly Valve	Electromotoric Actuators							
	SQL321B25	SQL321B50	SQL321B150	SQL321B270	SQL321B570	SQL321B1400	SQL321B2650	SQL321B6000
	SQL361B25	SQL361B50	SQL361B150	SQL361B270	SQL361B570	SQL361B1400	SQL361B2650	SQL361B6000
	SQL351B25	SQL351B50	SQL351B150	SQL351B270	SQL351B570	SQL351B1400	SQL351B2650	SQL351B6000
$\Delta p_s$ [kPa]								
VFF41.40	1000	-	-	-	-	-	-	-
VFF41.50	1000	-	-	-	-	-	-	-
VFF41.65	1000	-	-	-	-	-	-	-
VFF41.80	1000	-	-	-	-	-	-	-
VFF41.100	-	1000	-	-	-	-	-	-
VFF41.125	-	1000	-	-	-	-	-	-
VFF41.150	-	1000	-	-	-	-	-	-
VFF41.200	-	-	1000	-	-	-	-	-
VFF41.250	-	-	-	1000	-	-	-	-
VFF41.300	-	-	-	1000	-	-	-	-
VFF41.350	-	-	-	-	1000	-	-	-
VFF41.400	-	-	-	-	1000	-	-	-
VFF41.450	-	-	-	-	-	1000	-	-
VFF41.500	-	-	-	-	-	1000	-	-
VFF41.600	-	-	-	-	-	-	1000	-
VFF41.700	-	-	-	-	-	-	1000	-
VFF41.800	-	-	-	-	-	-	-	1000
VFF41.900	-	-	-	-	-	-	-	1000

$\Delta p_s$  = Maximum permissible differential pressure at which the motorized butterfly valve will close securely against the pressure (close off pressure).

## Actuator overview

Product No.	Operating Voltage	Positioning Signal	Position Feedback Signal	Positioning Time for 90° at 50 Hz [s]	Nominal Torque [Nm]	Flange Connection EN ISO 5211	Datasheet
SQL321B25	AC 220 V 1 phase	2-position (SPDT)	-	11	25	F07	N4520
SQL361B25		DC 0...10 V	DC 0...10 V	11	25	F07	
SQL351B25		4..20mA	4..20mA	11	25	F07	
SQL321B50		2-position (SPDT)	-	19	50	F07	
SQL361B50		DC 0...10 V	DC 0...10 V	19	50	F07	
SQL351B50		4..20mA	4..20mA	19	50	F07	
SQL321B150		2-position (SPDT)	-	39	150	F07	
SQL361B150		DC 0...10 V	DC 0...10 V	39	150	F07	
SQL351B150		4..20mA	4..20mA	39	150	F07	
SQL321B270		2-position (SPDT)	-	39	270	F10	
SQL361B270		DC 0...10 V	DC 0...10 V	39	270	F10	
SQL351B270		4..20mA	4..20mA	39	270	F10	
SQL321B570		2-position (SPDT)	-	47	570	F12 / F10	
SQL361B570		DC 0...10 V	DC 0...10 V	47	570	F12 / F10	
SQL351B570		4..20mA	4..20mA	47	570	F12 / F10	
SQL321B1400		2-position (SPDT)	-	76	1400	F14	
SQL361B1400		DC 0...10 V	DC 0...10 V	76	1400	F14	
SQL351B1400		4..20mA	4..20mA	76	1400	F14	
SQL321B2650		2-position (SPDT)	-	105	2650	F16	
SQL361B2650		DC 0...10 V	DC 0...10 V	105	2650	F16	
SQL351B2650		4..20mA	4..20mA	105	2650	F16	
SQL321B6000		2-position (SPDT)	-	105	8000	F25/F16	
SQL361B6000		DC 0...10 V	DC 0...10 V	105	8000	F25/F16	
SQL351B6000		4..20mA	4..20mA	105	8000	F25/F16	

Ring format, nodular cast iron valve body with EPDM-HT seat and multiple shaft bushing.  
 The seat is also used to seal the flange. There is thus no contact between the me-dium and the valve body.

Sizing

Flow diagram

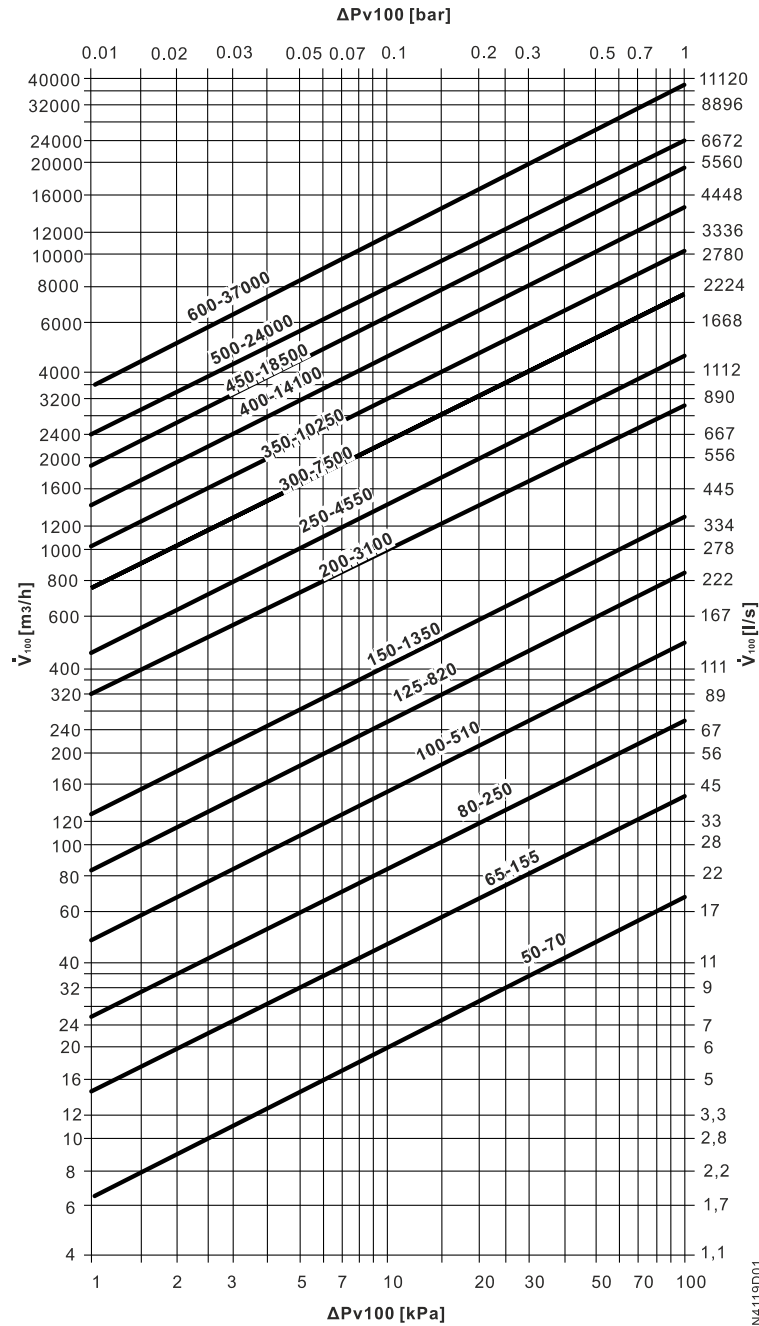

Flow characteristic

- $\Delta P_{v100}$  = Differential pressure across the fully open butterfly valve by a volume flow  $\dot{V}_{100}$
- $\dot{V}_{100}$  = Volume flow through the fully open butterfly valve
- 100 kPa = 1 bar  $\approx$  10 mWC
- 1 m³/h = 0.278 l/s water at 20 °C

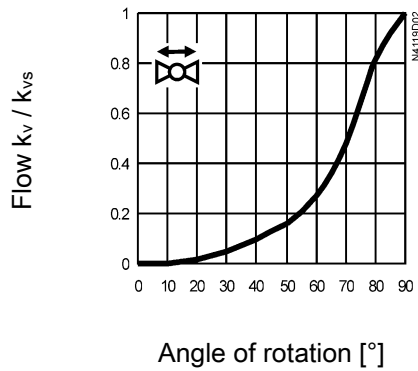

## Engineering Notes

Single flange mounting is possible: 1000 kPa

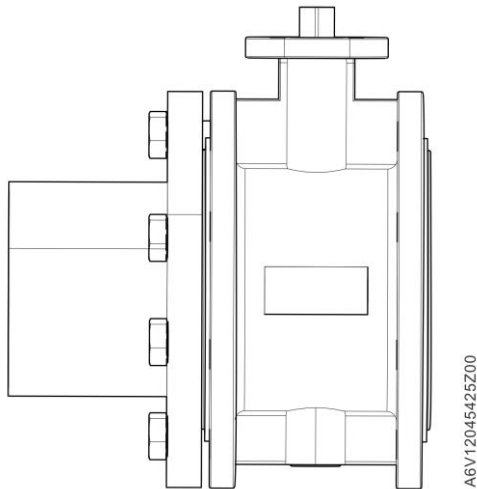

The VFF41.. butterfly valves can accommodate flow in either direction.

## Warning

To avoid pressure shocks on the butterfly valve, the VFF41.. must be driven to its fully open position either manually or via control signal Y14 prior to activating the pump(s).

## Mounting notes

The mounting instruction A6V12045430 is enclosed in the product packaging.

DN 40...900 butterfly valves can be mounted in PN 16 applications

## Orientation

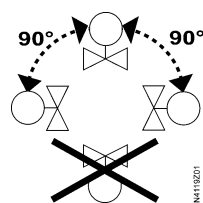

Upright to horizontal

## Maintenance notes

---

### Caution

The VFF41.. butterfly valves require no maintenance.

Before performing any service works on the valve, actuator or mounting kit:

- Switch off the pump and power supply
- Close the main shut-off valves in the pipe work
- Release pressure in the pipes and allow them to cool down completely

If necessary, disconnect electrical connections from terminals.

The valve must be commissioned only with the actuator correctly assembled.

## Disposal

---



The device is considered an electronics device for disposal in terms of European Directive 2012/19/EU and may not be disposed of as domestic garbage.

- Disassemble the valve into individual parts prior to disposing of it and sort the individual parts by the various types of materials.
- Comply with all local and currently applicable laws and regulations.

## Warranty

---

The technical data given for these applications is valid only in conjunction with the Siemens actuators as detailed under "Equipment combinations", page 2.

All terms of the warranty will be invalidated by the use of actuators from other manufacturers.

## Technical data

Functional data	
PN class	PN16 to EN1333
Permissible operating pressure	1600 kPa (16 bar)
Flow characteristic	According to the diagram on page
Leakage rate	A to ISO 5208 (tight-closing)
Permissible medium	Chilled water, low temperature hot water, cooling water, brine, demineralized water (softened), water with anti-freeze Recommendation: Water treatment to VDI 2035
Medium temperature	-10...120 °C
Flow Velocity	Water 4.5 m/s; Gas 60m/s (Ref. GB/T 12238, ISO 10631)
Flange connection for pipes <sup>1)</sup>	PN16 to ISO 7005
Face to face dimension	DIN EN 558, series 13
Top flange (flange for actuator)	EN ISO 5211
Angle of rotation	90°
Standards	
Environmental compability	ISO 14001 (Environment) ISO 9001 (Quality) Directive 2011/65/EU (RoHS)
Materials	
Body	Nodular cast iron EN-GJS-450-10 (QT450-10)
Stem	Stainless steel 1.4021 (2Cr13)
Valve disc	CF8 (304)
Seat	EPDM-HT
O-ring	EPDM-HT
Dimensions/weight	
Dimensions	Refer to Dimensions [See page 9]
Weight	Refer to Dimensions [See page 9]



## Dimensions

Dimensions in mm:

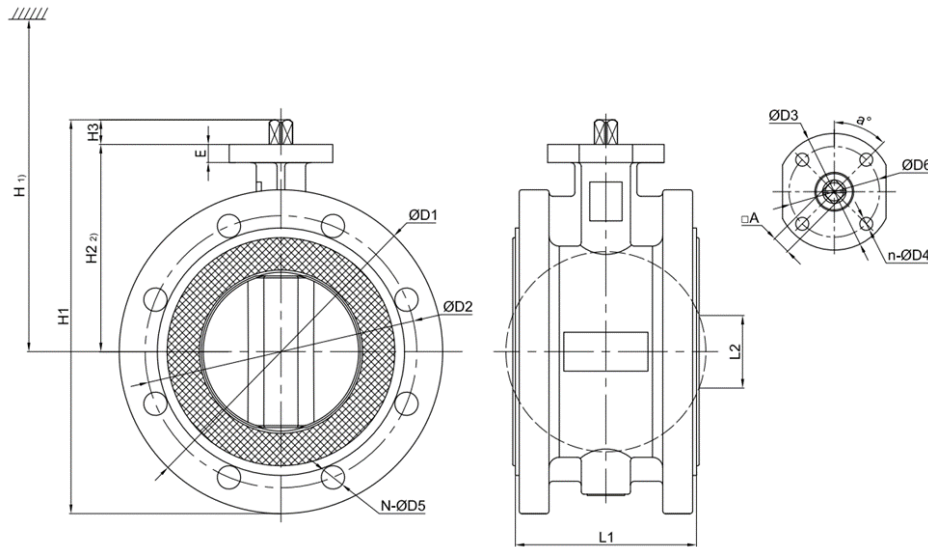

Product model	DN	L1	L2	H	H1	H2 <sup>2)</sup>	H3	ØD3	E	PN 16* Connecting			EN ISO 5211	n-ØD4	ØD6	□A	a°	Net weight (kg)
										ØD1	ØD2	N-ØD5						
VFF41.40	40	106	0	577	202	113	14	90	9	150	110	4-19	F07	4-10	70	11	45	6
VFF41.50	50	108	0	582	211.5	115	14	90	9	165	125	4-19					45	8
VFF41.65	65	112	0	590	228.5	122	14	90	9	185	145	4-19					45	10
VFF41.80	80	114	0	597	242	128	14	90	9	200	160	8-19					45	11
VFF41.100	100	127	0	611	268	144	14	90	11	220	180	8-19					45	13
VFF41.125	125	140	0	624	303	159	19	90	13	250	210	8-19					45	20
VFF41.150	150	140	65	644	340.5	179	19	90	13	285	240	8-23					45	23
VFF41.200	200	152	132	668	396	204	22	125	14	340	295	12-23					45	31
VFF41.250	250	165	188	781	471.5	245	24	125	15	405	355	12-28	F10	4-12	102	22	45	51
VFF41.300	300	178	243	806	524	270	24	125	16	460	410	12-28	F10	4-12	102	22	45	58
VFF41.350	350	190	273	851	638	315	29	150	20	520	470	16-28	F12	4-14	125	27	45	82
VFF41.400	400	216	324	886	698	350	29	150	20	580	525	16-31	F12	4-14	125	27	45	105
VFF41.450	450	222	381	1116	772	375	45	175	20	640	585	20-31	F14	4-18	140	36	45	121
VFF41.500	500	229	434	1156	847	415	45	175	20	715	650	20-34	F14	4-18	140	36	45	166
VFF41.600	600	267	528	1303	1064	562	50	210	25	840	770	20-37	F16	4-22	165	46	45	245
VFF41.700	700	292	628	1301	1145	560	95	210	25	910	840	24-37	F16	4-22	165	46	45	346
VFF41.800	800	318	726	1545	1265	620	120	300	30	1025	950	24-40	F25	8-18	254	60	22.5	451
VFF41.900	900	330	797	1600	1420	675	120	300	30	1125	1050	28-40	F25	8-18	254	60	22.5	633

L1	Base on EN558, series 13
H <sup>1)</sup>	Total height for valve and actuator
=	H2
+	Installation height for actuator
	- SQL321B25 = 195 mm (DN40...80)
	- SQL351B25, SQL361B25 = 264 mm (DN40...80)
	- SQL3...1B270, SQL3...1B570 = 336 mm (DN250...400)
+	Minimum installation height from actuator to ceiling or wall (≥ 200 mm), used for installation/connection/operation and maintenance etc..
H2 <sup>2)</sup>	Dimension for actuator installation bottom to center of piping
*	PN16 connecting is meaning that the hole can be connecting to PN16 flange. But it is not meaning the holes dimension is same as PN16 standard holes dimension as showed on table exactly.

## Application restriction

### Operation parameter

	Parameter	Value	Comment
1	Environmental conditions	Class 3k5	EN 60721-3-3
2	Temperature	-10...+55 °C	EN 60721-3-3
3	Humidity	5...95 % RH	EN 60721-3-3

### Transport parameter

	Parameter	Value	Comment
1	Environmental conditions	Class 2K3	EN 60721-3-2
2	Temperature	-30...+65 °C	EN 60721-3-2
3	Humidity	<95 % RH	EN 60721-3-2

### Storage parameter

	Parameter	Value	Comment
1	Environmental conditions	Class 1K3	EN 60721-3-1
2	Temperature	-15...+50 °C	EN 60721-3-1
3	Humidity	5...95 % RH	EN 60721-3-1

## Revision numbers

Product No.	Valid from Rev. No.	Product No.	Valid from Rev. No.	Product No.	Valid from Rev. No.
VFF41.40	..A	VFF41.150	..A	VFF41.450	..A
VFF41.50	..A	VFF41.200	..A	VFF41.500	..A
VFF41.65	..A	VFF41.250	..A	VFF41.600	..A
VFF41.80	..A	VFF41.300	..A	VFF41.700	..A
VFF41.100	..A	VFF41.350	..A	VFF41.800	..A
VFF41.125	..A	VFF41.400	..A	VFF41.900	..A